

Customization is available  
Products and specifications are  
subject to be changed without notice

**Options**

- 2.0-5.0m / 79-197 inch duplex mast
- 2.5-4.0m / 98-157 inch full free duplex mast
- 4.3-6.5m./169-256 inch triplex mast
- Special carriage and backrest
- Other dimension forks
- Dual drive wheel with fender
- Solid tyre
- Colored tyre ( white / green)
- Cabin
- Heater and air condition
- Fire extinguisher
- Semi-suspension seat or full-suspension seat
- Dual air cleaner or special air cleaner
- Rear working light
- Customer painting
- Auxiliary hydraulic valve modules
- High-mounted exhaust system
- Middle-mounted exhaust system
- Anti-fire spark exhaust device
- Diesel exhaust das purifier
- Radiator screen
- Side shifter
- Integrated side shifter
- Other attachment



**E-P Equipment Co.,LTD**  
Let's grow together...



CE  
ISO9000

**T Series**  
2.0/2.5/3.0/3.5T  
4400/5500/6600/7700lb  
Diesel/Gasoline/LPG



**24 hrs**  
 Service Change Your Business

**East Power**  
**EP Forklift Truck-T series**  
**2 year warranty**

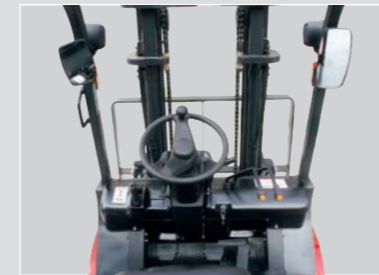

**Wide-View Mast**  
 The operator is able to work with increased safety and accuracy due to a wider view mast.



**Adjustable Steering Wheel**  
 Steering wheel can be adjusted by a lever on the right-hand side for the most comfortable operator position.



**Simple, Small-Stroke F/R Lever**  
 The forward-reverse lever swings through a smaller arc than previous models, meaning less effort and less total time used during this basic, often-performed function.



**Automobile-Style Light/Turn-Signal Lever**  
 The automotive influence seen in the T Series extends to the thoughtful use of an automobile-style light and turn-signal lever, with simple actions that let the operator focus on the job.



**Wide-Open Operation Space**  
 The area between the foot pedals and the body below the seat is open and free of obstructions that hamper entering and exiting the forklift.



**Brake Oil**  
 Easy to check and add brake oil.



**Easily-Detached Floor Panel**  
 One-touch removal of the floorboard gets you right to service operations and reduces down-time.



**Option**  
 Special carriage and backrest  
 Other dimension forks  
 Dual drive wheel with fender  
 Cabin  
 Heater and air condition  
 Dual air cleaner or special air cleaner  
 Rear working light



Custom color paint  
 High-mounted exhaust system  
 Middle-mounted exhaust system  
 Sideshifter  
 Other attachment  
 Lpg fuel system (single, dual)

**T series 2.0-3.5t forklift specification:**

|                              |                              |   |  |          |               |              |              |              |              |               |              |              |              |              |               |               |              |              |              |              |               |               |              |              |            |            |       |      |
|------------------------------|------------------------------|---|---|----------|---------------|--------------|--------------|--------------|--------------|---------------|--------------|--------------|--------------|--------------|---------------|---------------|--------------|--------------|--------------|--------------|---------------|---------------|--------------|--------------|------------|------------|-------|------|
| General                      | 1                            | Manufacture   |   |          |               |              |              |              |              |               |              |              |              |              |               |               |              |              |              |              |               |               |              |              |            |            |       |      |
|                              | 2                            | Model   |   |          | FD20T-TD27    | FD20T-NE92   | FD20T-A490   | FD20T-C490   | FG20T-F2     | FD25T-TD27    | FD25T-NE92   | FD25T-A490   | FD25T-C490   | FG25T-F2     | FD30T-TD27    | FD30T-QD32    | FD30T-A490   | FD30T-C490   | FD30T-A498   | FG30T-F2     | FD35T-TD27    | FD35T-QD32    | FD35T-A498   | FG35T-F2     |            |            |       |      |
|                              | 3                            | Power type  |   |          | Diesel        | Diesel       | Diesel       | Diesel       | Gasoline     | Diesel        | Diesel       | Diesel       | Diesel       | Gasoline     | Diesel        | Diesel        | Diesel       | Diesel       | Diesel       | Gasoline     | Diesel        | Diesel        | Diesel       | Gasoline     |            |            |       |      |
|                              | 4                            | Rated capacity  |   | Kg       | 2000          | 2000         | 2000         | 2000         | 2500         | 2500          | 2500         | 2500         | 2500         | 2500         | 3000          | 3000          | 3000         | 3000         | 3000         | 3000         | 3500          | 3500          | 3500         | 3500         |            |            |       |      |
|                              | 5                            | Load center   |   | mm       | 500           | 500          | 500          | 500          | 500          | 500           | 500          | 500          | 500          | 500          | 500           | 500           | 500          | 500          | 500          | 500          | 500           | 500           | 500          | 500          | 500        |            |       |      |
| Characteristics & Dimensions | 6                            | Lift height   |   | mm       | 3000          | 3000         | 3000         | 3000         | 3000         | 3000          | 3000         | 3000         | 3000         | 3000         | 3000          | 3000          | 3000         | 3000         | 3000         | 3000         | 3000          | 3000          | 3000         | 3000         |            |            |       |      |
|                              | 7                            | Free lift height  |   | mm       | 120           | 120          | 120          | 120          | 120          | 120           | 120          | 120          | 120          | 120          | 120           | 120           | 120          | 120          | 120          | 120          | 120           | 120           | 120          | 120          |            |            |       |      |
|                              | 8                            | Fork size   | L*W*T   | mm       | 920*100*40    | 920*100*40   | 920*100*40   | 920*100*40   | 920*100*40   | 920*100*40    | 920*100*40   | 920*100*40   | 920*100*40   | 920*100*40   | 920*125*40    | 920*125*40    | 920*125*40   | 920*125*40   | 920*125*40   | 920*125*40   | 920*125*40    | 920*125*40    | 920*125*40   | 920*125*40   |            |            |       |      |
|                              | 9                            | Mast tilt range   | F/R   | deg      | 6/12          | 6/12         | 6/12         | 6/12         | 6/12         | 6/12          | 6/12         | 6/12         | 6/12         | 6/12         | 6/12          | 6/12          | 6/12         | 6/12         | 6/12         | 6/12         | 6/12          | 6/12          | 6/12         | 6/12         |            |            |       |      |
|                              | 10                           | Fork overhang(wheel center to fork face)                              |   | mm       | 440           | 440          | 440          | 440          | 440          | 440           | 440          | 440          | 440          | 440          | 440           | 440           | 440          | 440          | 440          | 440          | 492           | 492           | 492          | 492          |            |            |       |      |
|                              | 11                           | Rear overhang   |   | mm       | 485           | 485          | 485          | 485          | 485          | 550           | 550          | 550          | 550          | 550          | 590           | 590           | 590          | 590          | 590          | 590          | 590           | 590           | 590          | 590          |            |            |       |      |
|                              | 12                           | Overall dimensions  | Length to face of fork  | mm       | 2530          | 2530         | 2530         | 2530         | 2530         | 2600          | 2600         | 2600         | 2600         | 2600         | 2730          | 2730          | 2730         | 2730         | 2730         | 2730         | 2790          | 2790          | 2790         | 2790         |            |            |       |      |
|                              | 13                           |   | Overall width   | mm       | 1150          | 1150         | 1150         | 1150         | 1150         | 1150          | 1150         | 1150         | 1150         | 1150         | 1150          | 1250          | 1250         | 1250         | 1250         | 1250         | 1250          | 1250          | 1250         | 1250         |            |            |       |      |
|                              | 14                           |   | Mast lowered height   | mm       | 1995          | 1995         | 1995         | 1995         | 1995         | 1995          | 1995         | 1995         | 1995         | 1995         | 1995          | 2005          | 2005         | 2005         | 2005         | 2005         | 2005          | 2017          | 2017         | 2017         | 2017       |            |       |      |
|                              | 15                           |   | Mast extended height  | mm       | 4200          | 4200         | 4200         | 4200         | 4200         | 4200          | 4200         | 4200         | 4200         | 4200         | 4200          | 4210          | 4210         | 4210         | 4210         | 4210         | 4210          | 4210          | 4210         | 4210         | 4210       |            |       |      |
|                              | 16                           | Overhead guard height   |   | mm       | 2130          | 2130         | 2130         | 2130         | 2130         | 2130          | 2130         | 2130         | 2130         | 2130         | 2130          | 2180          | 2180         | 2180         | 2180         | 2180         | 2180          | 2180          | 2180         | 2180         | 2180       |            |       |      |
|                              | 17                           | Turning radius(outside)   |   | mm       | 2170          | 2170         | 2170         | 2170         | 2170         | 2240          | 2240         | 2240         | 2240         | 2240         | 2240          | 2450          | 2450         | 2450         | 2450         | 2450         | 2450          | 2510          | 2510         | 2510         | 2510       |            |       |      |
|                              | 18                           | Min.right angle stacking aisle width (Add load length and clearance ) |   | mm       | 2680          | 2680         | 2680         | 2680         | 2680         | 2750          | 2750         | 2750         | 2750         | 2750         | 2750          | 2950          | 2950         | 2950         | 2950         | 2950         | 2950          | 3000          | 3000         | 3000         | 3000       |            |       |      |
| 19                           | AST with pallet 800*1000mm   |   | mm  | 3753     | 3753          | 3753         | 3753         | 3753         | 3823         | 3823          | 3823         | 3823         | 3823         | 3823         | 3873          | 3873          | 3873         | 3873         | 3873         | 3873         | 3923          | 3923          | 3923         | 3923         |            |            |       |      |
| Performance                  | 20                           | Speed   | Travel (No load)  | Km/h     | 20            | 20           | 20           | 20           | 20           | 20            | 20           | 20           | 20           | 20           | 18.5          | 18.5          | 18.5         | 18.5         | 18.5         | 18.5         | 18            | 18            | 18           | 18           |            |            |       |      |
|                              | 21                           |   | Lifting (Full load)   | mm/sec   | 450           | 450          | 450          | 450          | 450          | 450           | 450          | 450          | 450          | 450          | 400           | 400           | 400          | 400          | 400          | 400          | 400           | 400           | 400          | 400          |            |            |       |      |
|                              | 22                           |   | Lowering (Full load)  | mm/sec   | 450           | 450          | 450          | 450          | 450          | 450           | 450          | 450          | 450          | 450          | 400           | 400           | 400          | 400          | 400          | 400          | 450           | 450           | 450          | 450          |            |            |       |      |
|                              | 23                           | Max.Drawbar Pull (Full load)  |   | N        | 17500         | 17500        | 17500        | 17500        | 17500        | 17500         | 17500        | 17500        | 17500        | 17500        | 17500         | 21000         | 21000        | 21000        | 21000        | 21000        | 21000         | 23100         | 23100        | 23100        | 23100      |            |       |      |
| 24                           | Max.Gradeability (Full load) |   | %   | 20       | 20            | 20           | 20           | 20           | 20           | 20            | 20           | 20           | 20           | 20           | 20            | 20            | 20           | 20           | 20           | 20           | 18            | 18            | 18           | 18           |            |            |       |      |
| Chassis                      | 25                           | Tyres   | Front   |          | 7.00-12-12PR  | 7.00-12-12PR | 7.00-12-12PR | 7.00-12-12PR | 7.00-12-12PR | 7.00-12-12PR  | 7.00-12-12PR | 7.00-12-12PR | 7.00-12-12PR | 7.00-12-12PR | 28*9-15-12PR  | 28*9-15-12PR  | 28*9-15-12PR | 28*9-15-12PR | 28*9-15-12PR | 28*9-15-12PR | 28*9-15-12PR  | 28*9-15-12PR  | 28*9-15-12PR | 28*9-15-12PR |            |            |       |      |
|                              | 26                           |   | Rear  |          | 6.00-9-10PR   | 6.00-9-10PR  | 6.00-9-10PR  | 6.00-9-10PR  | 6.00-9-10PR  | 6.00-9-10PR   | 6.00-9-10PR  | 6.00-9-10PR  | 6.00-9-10PR  | 6.00-9-10PR  | 6.50-10-10PR  | 6.50-10-10PR  | 6.50-10-10PR | 6.50-10-10PR | 6.50-10-10PR | 6.50-10-10PR | 6.50-10-10PR  | 6.50-10-10PR  | 6.50-10-10PR | 6.50-10-10PR |            |            |       |      |
|                              | 27                           | Tread   | Front   | mm       | 970           | 970          | 970          | 970          | 970          | 970           | 970          | 970          | 970          | 970          | 1010          | 1010          | 1010         | 1010         | 1010         | 1010         | 1010          | 1010          | 1010         | 1010         |            |            |       |      |
|                              | 28                           |   | Rear  | mm       | 970           | 970          | 970          | 970          | 970          | 970           | 970          | 970          | 970          | 970          | 980           | 980           | 980          | 980          | 980          | 980          | 980           | 980           | 980          | 980          |            |            |       |      |
|                              | 29                           | Wheelbase   |   | mm       | 1600          | 1600         | 1600         | 1600         | 1600         | 1600          | 1600         | 1600         | 1600         | 1600         | 1600          | 1700          | 1700         | 1700         | 1700         | 1700         | 1700          | 1760          | 1760         | 1760         | 1760       |            |       |      |
| 30                           | Ground clearance             | Lowest  | mm  | 120      | 120           | 120          | 120          | 120          | 120          | 120           | 120          | 120          | 120          | 140          | 140           | 140           | 140          | 140          | 140          | 140          | 140           | 140           | 140          | 140          |            |            |       |      |
| 31                           |                              | Wheelbase center  | mm  | 145      | 145           | 145          | 145          | 145          | 145          | 145           | 145          | 145          | 145          | 145          | 175           | 175           | 175          | 175          | 175          | 175          | 175           | 175           | 175          | 175          |            |            |       |      |
| Weight                       | 32                           | Self weight   |   | Kg       | 3570          | 3570         | 3570         | 3570         | 3570         | 3900          | 3900         | 3900         | 3900         | 3900         | 4450          | 4450          | 4450         | 4450         | 4450         | 4450         | 4650          | 4650          | 4650         | 4650         |            |            |       |      |
|                              | 33                           | Weight Distribution   | Full load   | Front    | Kg            | 4846         | 4846         | 4846         | 4846         | 4846          | 5568         | 5568         | 5568         | 5568         | 5568          | 6488          | 6488         | 6488         | 6488         | 6488         | 6488          | 6488          | 6488         | 7091         | 7091       | 7091       | 7091  |      |
|                              | 34                           |   |   | Rear     | Kg            | 724          | 724          | 724          | 724          | 724           | 832          | 832          | 832          | 832          | 832           | 832           | 962          | 962          | 962          | 962          | 962           | 962           | 962          | 962          | 1060       | 1060       | 1060  | 1060 |
|                              | 35                           |   | No load   | Front    | Kg            | 1428         | 1428         | 1428         | 1428         | 1428          | 1560         | 1560         | 1560         | 1560         | 1560          | 1810          | 1810         | 1810         | 1810         | 1810         | 1810          | 1810          | 1810         | 1810         | 1810       | 1860       | 1860  | 1860 |
|                              | 36                           |   |   | Rear     | Kg            | 2142         | 2142         | 2142         | 2142         | 2142          | 2340         | 2340         | 2340         | 2340         | 2340          | 2640          | 2640         | 2640         | 2640         | 2640         | 2640          | 2640          | 2790         | 2790         | 2790       | 2790       | 2790  | 2790 |
| Power & transmission         | 37                           | Battery   | Voltage/Capacity(20HR)  | V/AH     | 12/60         | 12/60        | 12/80        | 12/80        | 12/80        | 12/60         | 12/80        | 12/80        | 12/80        | 12/80        | 12/60         | 12/60         | 12/60        | 12/60        | 12/60        | 12/60        | 12/60         | 12/60         | 12/60        | 12/80        | 12/80      | 12/60      | 12/60 |      |
|                              | 38                           | Engine  | Model   |          | TD27          | 4TNE92       | A490BPG      | C490BPG      | F2(2.2L)     | TD27          | 4TNE92       | A490BPG      | C490BPG      | F2(2.2L)     | TD27          | QD32          | A490BPG      | C490BPG      | A498BPG      | F2(2.2L)     | TD27          | QD32          | A498BPG      | F2(2.2L)     |            |            |       |      |
|                              | 39                           | Manufacturer  |   |          | NISSAN DIESEL | YANMAR       | CHINA        | CHINA        | MAZDA        | NISSAN DIESEL | YANMAR       | CHINA        | CHINA        | MAZDA        | NISSAN DIESEL | NISSAN DIESEL | CHINA        | CHINA        | CHINA        | MAZDA        | NISSAN DIESEL | NISSAN DIESEL | CHINA        | MAZDA        |            |            |       |      |
|                              | 40                           | Rated output/r.p.m  | kw  | 44/2500  | 33/2450       | 37/2650      | 36.8/2650    | 37.2/2700    | 44/2500      | 33/2450       | 37/2650      | 36.8/2650    | 37.2/2700    | 44/2500      | 44/2300       | 37/2650       | 36.8/2650    | 45/2500      | 37.2/2700    | 44/2500      | 44/2300       | 45/2500       | 37.2/2700    | 44/2500      |            |            |       |      |
|                              | 41                           | Rated torque/r.p.m  | N.m   | 172/1600 | 136/1600      | 148/1800     | 156/1700     | 142/1800     | 172/1600     | 136/1600      | 148/1800     | 156/1700     | 142/1800     | 172/1600     | 189/1800      | 148/1800      | 156/1700     | 193/1600     | 142/1800     | 172/1600     | 189/1800      | 193/1600      | 142/1800     | 172/1600     |            |            |       |      |
|                              | 42                           | No.of cylinder  |   |          | 4             | 4            | 4            | 4            | 4            | 4             | 4            | 4            | 4            | 4            | 4             | 4             | 4            | 4            | 4            | 4            | 4             | 4             | 4            | 4            | 4          | 4          |       |      |
|                              | 43                           | Bore*Stroke   | mm  | 96*92    | 92*100        | 90*100       | 90*105       | 86*94        | 96*92        | 92*100        | 90*100       | 90*105       | 86*94        | 96*92        | 99*102        | 90*100        | 90*105       | 98*105       | 86*94        | 96*92        | 99*102        | 98*105        | 86*94        | 96*92        | 99*102     | 98*105     | 86*94 |      |
|                              | 44                           | Displacement  | cc  | 2663     | 2659          | 2540         | 2670         | 2184         | 2663         | 2659          | 2540         | 2670         | 2184         | 2663         | 3153          | 2540          | 2670         | 3168         | 2184         | 2663         | 3153          | 3168          | 2184         | 2663         | 3153       | 3168       | 2184  |      |
|                              | 45                           | Fuel tank capacity  | L   | 60       | 60            | 60           | 60           | 60           | 60           | 60            | 60           | 60           | 60           | 60           | 60            | 60            | 60           | 60           | 60           | 60           | 60            | 60            | 60           | 60           | 60         | 60         | 60    |      |
|                              | 46                           | Transmissions   | Manufacture   |          |               | CHINA        | CHINA        | CHINA        | CHINA        | CHINA         | CHINA        | CHINA        | CHINA        | CHINA        | CHINA         | CHINA         | CHINA        | CHINA        | CHINA        | CHINA        | CHINA         | CHINA         | CHINA        | CHINA        | CHINA      | CHINA      |       |      |
|                              | 47                           | Type  |   |          | Powershift    | Powershift   | Powershift   | Powershift   | Powershift   | Powershift    | Powershift   | Powershift   | Powershift   | Powershift   | Powershift    | Powershift    | Powershift   | Powershift   | Powershift   | Powershift   | Powershift    | Powershift    | Powershift   | Powershift   | Powershift | Powershift |       |      |
|                              | 48                           | Stage   | FWD/RVS   |          | 1/1           | 1/1          | 1/1          | 1/1          | 1/1          | 1/1           | 1/1          | 1/1          | 1/1          | 1/1          | 1/1           | 1/1           | 1/1          | 1/1          | 1/1          | 1/1          | 1/1           | 1/1           | 1/1          | 1/1          | 1/1        | 1/1        |       |      |
| 49                           | Operating pressure           | For attachments   | Mpa   | 17.5     | 17.5          | 17.5         | 17.5         | 17.5         | 17.5         | 17.5          | 17.5         | 17.5         | 17.5         | 17.5         | 17.5          | 17.5          | 17.5         | 17.5         | 17.5         | 17.5         | 17.5          | 17.5          | 17.5         | 17.5         | 17.5       |            |       |      |

1. Special lifting height available.      2. Attachment available.  
 3. The specification in the table are for standard models only . For further information please contact us

**T series 4400-7700lb forklift specification:**

|                              |                              |  |                  |                        |            |              |              |              |              |              |              |              |              |              |               |               |               |               |               |               |               |               |               |               |            |           |          |
|------------------------------|------------------------------|---|------------------|------------------------|------------|--------------|--------------|--------------|--------------|--------------|--------------|--------------|--------------|--------------|---------------|---------------|---------------|---------------|---------------|---------------|---------------|---------------|---------------|---------------|------------|-----------|----------|
| General                      | 1                            | Manufacture   |                  |                        |            |              |              |              |              |              |              |              |              |              |               |               |               |               |               |               |               |               |               |               |            |           |          |
|                              | 2                            | Model   |                  | FD20T-TD27             | FD20T-NE92 | FD20T-A490   | FD20T-C490   | FG20T-F2     | FD25T-TD27   | FD25T-NE92   | FD25T-A490   | FD25T-C490   | FG25T-F2     | FD30T-TD27   | FD30T-QD32    | FD30T-A490    | FD30T-C490    | FD30T-A498    | FG30T-F2      | FD35T-TD27    | FD35T-QD32    | FD35T-A498    | FG35T-F2      |               |            |           |          |
|                              | 3                            | Power type  |                  | Diesel                 | Diesel     | Diesel       | Diesel       | Gasoline     | Diesel       | Diesel       | Diesel       | Diesel       | Gasoline     | Diesel       | Diesel        | Diesel        | Diesel        | Diesel        | Gasoline      | Diesel        | Diesel        | Diesel        | Gasoline      |               |            |           |          |
|                              | 4                            | Rated capacity  |                  | lb                     | 4400       | 4400         | 4400         | 4400         | 4400         | 5500         | 5500         | 5500         | 5500         | 5500         | 6600          | 6600          | 6600          | 6600          | 6600          | 7700          | 7700          | 7700          | 7700          |               |            |           |          |
|                              | 5                            | Load center   |                  | inch                   | 20         | 20           | 20           | 20           | 20           | 20           | 20           | 20           | 20           | 20           | 20            | 20            | 20            | 20            | 20            | 20            | 20            | 20            | 20            |               |            |           |          |
| Characteristics & Dimensions | 6                            | Lift height   |                  | inch                   | 118        | 118          | 118          | 118          | 118          | 118          | 118          | 118          | 118          | 118          | 118           | 118           | 118           | 118           | 118           | 118           | 118           | 118           |               |               |            |           |          |
|                              | 7                            | Free lift height  |                  | inch                   | 4.7        | 4.7          | 4.7          | 4.7          | 4.7          | 4.7          | 4.7          | 4.7          | 4.7          | 4.7          | 4.7           | 4.7           | 4.7           | 4.7           | 4.7           | 5             | 5             | 5             | 5             |               |            |           |          |
|                              | 8                            | Fork size   |                  | L*W*T                  | inch       | 36.2*3.9*1.5 | 36.2*3.9*1.5 | 36.2*3.9*1.5 | 36.2*3.9*1.5 | 36.2*3.9*1.5 | 36.2*3.9*1.5 | 36.2*3.9*1.5 | 36.2*3.9*1.5 | 36.2*3.9*1.5 | 39.2*4.92*1.5 | 39.2*4.92*1.5 | 39.2*4.92*1.5 | 39.2*4.92*1.5 | 39.2*4.92*1.5 | 39.2*4.92*1.5 | 39.2*4.92*1.5 | 39.2*4.92*1.5 | 39.2*4.92*1.5 |               |            |           |          |
|                              | 9                            | Mast tilt range   |                  | F/R                    | deg        | 6/12         | 6/12         | 6/12         | 6/12         | 6/12         | 6/12         | 6/12         | 6/12         | 6/12         | 6/12          | 6/12          | 6/12          | 6/12          | 6/12          | 6/12          | 6/12          | 6/12          | 6/12          |               |            |           |          |
|                              | 10                           | Fork overhang(wheel center to fork face)  |                  | inch                   | 17.3       | 17.3         | 17.3         | 17.3         | 17.3         | 17.3         | 17.3         | 17.3         | 17.3         | 17.3         | 17.3          | 17.3          | 17.3          | 17.3          | 17.3          | 19            | 19            | 19            | 19            |               |            |           |          |
|                              | 11                           | Rear overhang   |                  | inch                   | 19.1       | 19.1         | 19.1         | 19.1         | 19.1         | 21.7         | 21.7         | 21.7         | 21.7         | 21.7         | 23.2          | 23.2          | 23.2          | 23.2          | 23.2          | 23            | 23            | 23            | 23            |               |            |           |          |
|                              | 12                           | Overall dimensions  |                  | Length to face of fork |            | inch         | 100          | 100          | 100          | 100          | 100          | 100          | 100          | 100          | 100           | 100           | 100           | 100           | 100           | 110           | 110           | 110           | 110           |               |            |           |          |
|                              | 13                           |   |                  | Overall width          |            | inch         | 45           | 45           | 45           | 45           | 45           | 45           | 45           | 45           | 45            | 49            | 49            | 49            | 49            | 49            | 49            | 49            | 49            | 49            |            |           |          |
|                              | 14                           |   |                  | Most lowered height    |            | inch         | 79           | 79           | 79           | 79           | 79           | 79           | 79           | 79           | 79            | 79            | 79            | 79            | 79            | 79            | 79            | 79            | 79            | 79            |            |           |          |
|                              | 15                           |   |                  | Most extended height   |            | inch         | 165          | 165          | 165          | 165          | 165          | 165          | 165          | 165          | 165           | 165           | 166           | 166           | 166           | 166           | 166           | 166           | 166           | 166           |            |           |          |
|                              | 16                           |   |                  | Overhead guard height  |            | inch         | 84           | 84           | 84           | 84           | 84           | 84           | 84           | 84           | 84            | 86            | 86            | 86            | 86            | 86            | 86            | 86            | 86            |               |            |           |          |
|                              | 17                           | Turning radius(outside)   |                  | inch                   | 85         | 85           | 85           | 85           | 85           | 88           | 88           | 88           | 88           | 88           | 96            | 96            | 96            | 96            | 96            | 99            | 99            | 99            | 99            |               |            |           |          |
|                              | 18                           | Min.right angle stacking aisle width<br>(Add load length and clearance )            |                  | inch                   | 106        | 106          | 106          | 106          | 106          | 108          | 108          | 108          | 108          | 108          | 116           | 116           | 116           | 116           | 116           | 118           | 118           | 118           | 118           |               |            |           |          |
| 19                           | AST with pallet 800*1000mm   |   | inch             | 148                    | 148        | 148          | 148          | 148          | 151          | 151          | 151          | 151          | 151          | 152          | 152           | 152           | 152           | 152           | 154           | 154           | 154           | 154           |               |               |            |           |          |
| Performance                  | 20                           | Speed   |                  | Travel (No load)       |            | mile/h       | 12.4         | 12.4         | 12.4         | 12.4         | 12.4         | 12.4         | 12.4         | 12.4         | 11.5          | 11.5          | 11.5          | 11.5          | 11.5          | 11.5          | 11.5          | 11.5          |               |               |            |           |          |
|                              | 21                           |   |                  | Lifting (Full load)    |            | inch/sec     | 17.7         | 17.7         | 17.7         | 17.7         | 17.7         | 17.7         | 17.7         | 17.7         | 17.7          | 15.7          | 15.7          | 15.7          | 15.7          | 15.7          | 16            | 16            | 16            | 16            |            |           |          |
|                              | 22                           |   |                  | Lowering (Full load)   |            | inch/sec     | 17.7         | 17.7         | 17.7         | 17.7         | 17.7         | 17.7         | 17.7         | 17.7         | 17.7          | 15.7          | 15.7          | 15.7          | 15.7          | 15.7          | 18            | 18            | 18            | 18            |            |           |          |
|                              | 23                           | Max.Drawbar Pull (Full load)  |                  | N                      | 17500      | 17500        | 17500        | 17500        | 17500        | 17500        | 17500        | 17500        | 17500        | 17500        | 21000         | 21000         | 21000         | 21000         | 21000         | 23100         | 23100         | 23100         | 23100         |               |            |           |          |
| 24                           | Max.Gradeability (Full load) |   | %                | 20                     | 20         | 20           | 20           | 20           | 20           | 20           | 20           | 20           | 20           | 20           | 20            | 20            | 20            | 20            | 20            | 20            | 20            | 20            |               |               |            |           |          |
| Chassis                      | 25                           | Tyres   |                  | Front                  |            | 7.00-12-12PR | 7.00-12-12PR | 7.00-12-12PR | 7.00-12-12PR | 7.00-12-12PR | 7.00-12-12PR | 7.00-12-12PR | 7.00-12-12PR | 28*9-15-12PR | 28*9-15-12PR  | 28*9-15-12PR  | 28*9-15-12PR  | 28*9-15-12PR  | 28*9-15-12PR  | 28*9-15-12PR  | 28*9-15-12PR  | 28*9-15-12PR  |               |               |            |           |          |
|                              | 26                           |   |                  | Rear                   |            | 6.00-9-10PR  | 6.00-9-10PR  | 6.00-9-10PR  | 6.00-9-10PR  | 6.00-9-10PR  | 6.00-9-10PR  | 6.00-9-10PR  | 6.00-9-10PR  | 6.00-9-10PR  | 6.50-10-10PR  | 6.50-10-10PR  | 6.50-10-10PR  | 6.50-10-10PR  | 6.50-10-10PR  | 6.50-10-10PR  | 6.50-10-10PR  | 6.50-10-10PR  | 6.50-10-10PR  |               |            |           |          |
|                              | 27                           | Tread   |                  | Front                  |            | inch         | 38           | 38           | 38           | 38           | 38           | 38           | 38           | 38           | 40            | 40            | 40            | 40            | 40            | 40            | 40            | 40            |               |               |            |           |          |
|                              | 28                           |   |                  | Rear                   |            | inch         | 38           | 38           | 38           | 38           | 38           | 38           | 38           | 38           | 39            | 39            | 39            | 39            | 39            | 39            | 39            | 39            | 39            |               |            |           |          |
|                              | 29                           | Wheelbase   |                  | inch                   | 63         | 63           | 63           | 63           | 63           | 63           | 63           | 63           | 63           | 63           | 67            | 67            | 67            | 67            | 67            | 69            | 69            | 69            | 69            |               |            |           |          |
| 30                           | Ground clearance             |   | Lowest           |                        | inch       | 4.7          | 4.7          | 4.7          | 4.7          | 4.7          | 4.7          | 4.7          | 4.7          | 5.5          | 5.5           | 5.5           | 5.5           | 5.5           | 6             | 6             | 6             | 6             |               |               |            |           |          |
|                              |                              |   | Wheelbase center |                        | inch       | 5.7          | 5.7          | 5.7          | 5.7          | 5.7          | 5.7          | 5.7          | 5.7          | 5.7          | 5.7           | 6.9           | 6.9           | 6.9           | 6.9           | 6.9           | 7             | 7             | 7             |               |            |           |          |
| Weight                       | 32                           |   | Self weight      |                        | lb         | 7900         | 7900         | 7900         | 7900         | 7900         | 7900         | 7900         | 8600         | 8600         | 8600          | 8600          | 8600          | 8600          | 10200         | 10200         | 10200         | 10200         |               |               |            |           |          |
|                              | 33                           | Weight Distribution   |                  | Full load              |            | Front        | lb           | 1000         | 1000         | 1000         | 1000         | 1000         | 1000         | 12300        | 12300         | 12300         | 12300         | 12300         | 14300         | 14300         | 14300         | 14300         |               |               |            |           |          |
|                              |                              |   |                  | Rear                   | lb         | 1600         | 1600         | 1600         | 1600         | 1600         | 1600         | 1800         | 1800         | 1800         | 1800          | 2100          | 2100          | 2100          | 2100          | 2100          | 2300          | 2300          | 2300          |               |            |           |          |
|                              | 34                           |   |                  | No load                |            | Front        | lb           | 3100         | 3100         | 3100         | 3100         | 3100         | 3100         | 3400         | 3400          | 3400          | 3400          | 3400          | 4000          | 4000          | 4000          | 4000          |               |               |            |           |          |
| 35                           |                              |   |                  |                        | Rear       | lb           | 4700         | 4700         | 4700         | 4700         | 4700         | 4700         | 5200         | 5200         | 5200          | 5200          | 5200          | 5800          | 5800          | 5800          | 6100          | 6100          |               |               |            |           |          |
| Power & transmission         | 37                           | Battery   |                  | Voltage/Capacity(20HR) |            | V/AH         | 12/60        | 12/60        | 12/80        | 12/80        | 12/80        | 12/80        | 12/80        | 12/60        | 12/60         | 12/60         | 12/60         | 12/60         | 12/60         | 12/60         | 12/60         | 12/60         |               |               |            |           |          |
|                              | 38                           | Engine  |                  | Model                  |            | TD27         | 4TNE92       | A490BPG      | C490BPG      | F2(2.2L)     | TD27         | 4TNE92       | A490BPG      | C490BPG      | F2(2.2L)      | TD27          | QD32          | A490BPG       | C490BPG       | A498BPG       | F2(2.2L)      | TD27          | QD32          | A498BPG       | F2(2.2L)   |           |          |
|                              | 39                           |   |                  | Manufactur             |            | NISSAN       | YANMAR       | CHINA        | CHINA        | Mazda        | NISSAN       | YANMAR       | CHINA        | CHINA        | Mazda         | NISSAN        | NISSAN        | CHINA         | CHINA         | CHINA         | CHINA         | Mazda         | NISSAN DIESEL | NISSAN DIESEL | CHINA      | Mazda     |          |
|                              | 40                           |   |                  | Rated output/r.p.m     |            | hp           | 59/2500      | 44/2450      | 49.6/2650    | 49.5/2650    | 49.9/2700    | 59/2500      | 44/2450      | 49.6/2650    | 49.5/2650     | 49.9/2700     | 59/2500       | 44/2300       | 49.6/2650     | 49.5/2650     | 49.5/2650     | 49.9/2700     | 59/2500       | 44/2300       | 60/2500    | 49.9/2700 |          |
|                              | 41                           |   |                  | Rated torque/r.p.m     |            | N.m          | 172/1600     | 136/1600     | 148/1800     | 156/1700     | 142/1800     | 172/1600     | 136/1600     | 148/1800     | 156/1700      | 142/1800      | 172/1600      | 189/1800      | 148/1800      | 156/1700      | 156/1700      | 142/1800      | 172/1600      | 189/1800      | 193/1600   | 142/1800  |          |
|                              | 42                           |   |                  | No.of cylinder         |            |              | 4            | 4            | 4            | 4            | 4            | 4            | 4            | 4            | 4             | 4             | 4             | 4             | 4             | 4             | 4             | 4             | 4             | 4             | 4          | 4         |          |
|                              | 43                           |   |                  | Bore*Stroke            |            | inch         | 3.78*3.62    | 3.62*3.94    | 3.54*3.94    | 3.54*4.13    | 3.39*3.7     | 3.78*3.62    | 3.62*3.94    | 3.54*3.94    | 3.54*3.94     | 3.54*4.13     | 3.39*3.7      | 3.78*3.62     | 3.9*4.0       | 3.54*3.94     | 3.54*4.13     | 3.86*4.13     | 3.39*3.7      | 3.78*3.62     | 3.90*4.02  | 3.86*4.13 | 3.39*3.7 |
|                              | 44                           |   |                  | Displacement           |            | cc           | 2663         | 2659         | 2540         | 2670         | 2184         | 2663         | 2659         | 2540         | 2670          | 2184          | 2663          | 3153          | 2540          | 2670          | 3168          | 2184          | 2663          | 3153          | 3168       | 3168      | 2184     |
|                              | 45                           | Fuel tank capacity  |                  | L                      | 60         | 60           | 60           | 60           | 60           | 60           | 60           | 60           | 60           | 60           | 60            | 60            | 60            | 60            | 60            | 60            | 60            | 60            | 60            | 60            | 60         |           |          |
|                              | 46                           | Transmissions   |                  | Manufacture            |            | CHINA        | CHINA        | CHINA        | CHINA        | CHINA        | CHINA        | CHINA        | CHINA        | CHINA        | CHINA         | CHINA         | CHINA         | CHINA         | CHINA         | CHINA         | CHINA         | CHINA         | CHINA         | CHINA         | CHINA      |           |          |
|                              | 47                           |   |                  | Type                   |            |              | Powershift   | Powershift   | Powershift   | Powershift   | Powershift   | Powershift   | Powershift   | Powershift   | Powershift    | Powershift    | Powershift    | Powershift    | Powershift    | Powershift    | Powershift    | Powershift    | Powershift    | Powershift    | Powershift |           |          |
| 48                           |                              |   | Stage            |                        | FWD/RVS    | 1/1          | 1/1          | 1/1          | 1/1          | 1/1          | 1/1          | 1/1          | 1/1          | 1/1          | 1/1           | 1/1           | 1/1           | 1/1           | 1/1           | 1/1           | 1/1           | 1/1           | 1/1           |               |            |           |          |
| 49                           | Operating pressure           |   | For attachments  |                        | Mpa        | 17.5         | 17.5         | 17.5         | 17.5         | 17.5         | 17.5         | 17.5         | 17.5         | 17.5         | 17.5          | 17.5          | 17.5          | 17.5          | 17.5          | 17.5          | 17.5          | 17.5          | 17.5          |               |            |           |          |

1. Special lifting height available. 2. Attachment available.  
 3. The specification in the table are for standard models only . For further information please contact us

**2.0~2.5t T series mast: (Pneumatic)**

| Type                      | Model | Max.fork height | Overall height |                  |               |                  | Free lift     |      | Front Overhang |     | Tilt range |                        | Capacity |             |      |  |
|---------------------------|-------|-----------------|----------------|------------------|---------------|------------------|---------------|------|----------------|-----|------------|------------------------|----------|-------------|------|--|
|                           |       |                 | Lowered        | Extended         |               | Without backrest | With backrest | 2.0t | 2.5t           | FWD | BWD        | Load capacity at 500mm |          |             |      |  |
|                           |       |                 |                | Without backrest | With backrest |                  |               |      |                |     |            | Single tire            |          | Double tire |      |  |
|                           |       |                 |                |                  |               |                  |               |      |                |     |            | 2.0t                   | 2.5t     | 2.0t        | 2.5t |  |
| Wide view<br>2-stage mast | 2W300 | 3000            | 1995           | 3540             | 4220          | 120              | 120           | 440  | 440            | 6   | 12         | 2000                   | 2500     | 2000        | 2500 |  |
|                           | 2W330 | 3300            | 2145           | 3690             | 4370          | 120              | 120           | 440  | 440            | 6   | 12         | 2000                   | 2500     | 2000        | 2500 |  |
|                           | 2W350 | 3500            | 2245           | 3890             | 4570          | 120              | 120           | 440  | 440            | 6   | 12         | 2000                   | 2500     | 2000        | 2500 |  |
|                           | 2W360 | 3600            | 2295           | 3990             | 4670          | 120              | 120           | 440  | 440            | 6   | 12         | 2000                   | 2500     | 2000        | 2500 |  |
|                           | 2W400 | 4000            | 2495           | 4040             | 4720          | 120              | 120           | 440  | 440            | 6   | 12         | 1900                   | 2300     | 2000        | 2500 |  |
|                           | 2W430 | 4300            | 2645           | 4340             | 5020          | 120              | 120           | 440  | 440            | 6   | 6          | 1800                   | 2100     | 1950        | 2450 |  |
|                           | 2W450 | 4500            | 2745           | 4290             | 4970          | 120              | 120           | 440  | 440            | 6   | 6          | 1700                   | 2000     | 1900        | 2400 |  |
| Full free<br>2-stage mast | 2F300 | 3000            | 2050           | 2590             | 3270          | 1460             | 810           | 440  | 440            | 6   | 12         | 2000                   | 2500     | 2000        | 2500 |  |
|                           | 2F330 | 3300            | 2200           | 3840             | 4520          | 1610             | 960           | 440  | 440            | 6   | 12         | 2000                   | 2500     | 2000        | 2500 |  |
| Full free<br>3-stage mast | 3F430 | 4300            | 1970           | 4240             | 4880          | 1360             | 730           | 440  | 440            | 6   | 6          | 1700                   | 2000     | 1900        | 2400 |  |
|                           | 3F450 | 4500            | 2050           | 5720             | 5040          | 1460             | 810           | 460  | 460            | 6   | 6          | 1600                   | 1900     | 1800        | 2300 |  |
|                           | 3F480 | 4800            | 2095           | 6020             | 5345          | 1565             | 915           | 460  | 460            | 6   | 6          | 1500                   | 1700     | 1700        | 2100 |  |
|                           | 3F500 | 5000            | 2240           | 6220             | 5540          | 1610             | 960           | 460  | 460            | 6   | 6          | 1400                   | 1600     | 1600        | 2000 |  |
|                           | 3F550 | 5500            | 2320           | 6800             | 6120          | 1770             | 1120          | 460  | 460            | 3   | 6          | 1050                   | 1200     | 1500        | 1800 |  |
|                           | 3F600 | 6000            | 2740           | 7220             | 6540          | 2020             | 1370          | 460  | 460            | 3   | 6          | 700                    | 800      | 1400        | 1600 |  |

Note: With sideshift minus 150Kg, with integral sideshift minus 100Kg.

**4400-5500lb series mast: (Pneumatic)**

| Type                      | Model | Max.fork height | Overall height |                  |               |                  | Free lift     |        | Front Overhang |     | Tilt range |                          | Capacity |             |        |  |
|---------------------------|-------|-----------------|----------------|------------------|---------------|------------------|---------------|--------|----------------|-----|------------|--------------------------|----------|-------------|--------|--|
|                           |       |                 | Lowered        | Extended         |               | Without backrest | With backrest | 4400lb | 5500lb         | FWD | BWD        | Load capacity at 20 inch |          |             |        |  |
|                           |       |                 |                | Without backrest | With backrest |                  |               |        |                |     |            | Single tire              |          | Double tire |        |  |
|                           |       |                 |                |                  |               |                  |               |        |                |     |            | 4400lb                   | 5500lb   | 4400lb      | 5500lb |  |
| Wide view<br>2-stage mast | 2W300 | 118             | 79             | 139              | 166           | 4.7              | 4.7           | 17.3   | 17.3           | 6   | 12         | 4400                     | 5500     | 4400        | 5500   |  |
|                           | 2W330 | 130             | 84             | 145              | 172           | 4.7              | 4.7           | 17.3   | 17.3           | 6   | 12         | 4400                     | 5500     | 4400        | 5500   |  |
|                           | 2W350 | 138             | 88             | 153              | 180           | 4.7              | 4.7           | 17.3   | 17.3           | 6   | 12         | 4400                     | 5500     | 4400        | 5500   |  |
|                           | 2W360 | 142             | 90             | 157              | 184           | 4.7              | 4.7           | 17.3   | 17.3           | 6   | 12         | 4400                     | 5500     | 4400        | 5500   |  |
|                           | 2W400 | 157             | 98             | 159              | 186           | 4.7              | 4.7           | 17.3   | 17.3           | 6   | 12         | 4200                     | 5100     | 4400        | 5500   |  |
|                           | 2W430 | 169             | 104            | 171              | 198           | 4.7              | 4.7           | 17.3   | 17.3           | 6   | 6          | 3900                     | 4600     | 4300        | 5400   |  |
|                           | 2W450 | 177             | 108            | 169              | 196           | 4.7              | 4.7           | 17.3   | 17.3           | 6   | 6          | 3700                     | 4400     | 4200        | 5300   |  |
| Full free<br>2-stage mast | 2F300 | 118             | 81             | 102              | 129           | 57               | 32            | 17.3   | 17.3           | 6   | 12         | 4400                     | 5500     | 4400        | 5500   |  |
|                           | 2F330 | 130             | 87             | 151              | 178           | 63               | 38            | 17.3   | 17.3           | 6   | 12         | 4400                     | 5500     | 4400        | 5500   |  |
| Full free<br>3-stage mast | 3F430 | 169             | 78             | 167              | 192           | 54               | 29            | 17.3   | 17.3           | 6   | 6          | 3700                     | 4400     | 4200        | 5300   |  |
|                           | 3F450 | 177             | 81             | 225              | 198           | 57               | 32            | 18.1   | 18.1           | 6   | 6          | 3500                     | 4200     | 4000        | 5100   |  |
|                           | 3F480 | 189             | 82             | 237              | 210           | 62               | 36            | 18.1   | 18.1           | 6   | 6          | 3300                     | 3700     | 3700        | 4600   |  |
|                           | 3F500 | 197             | 88             | 245              | 218           | 63               | 38            | 18.1   | 18.1           | 6   | 6          | 3100                     | 3500     | 3500        | 4400   |  |
|                           | 3F550 | 217             | 91             | 268              | 241           | 70               | 44            | 18.1   | 18.1           | 3   | 6          | 2300                     | 2700     | 3300        | 4000   |  |
|                           | 3F600 | 236             | 108            | 284              | 257           | 80               | 54            | 18.1   | 18.1           | 3   | 6          | 1500                     | 1800     | 3100        | 3500   |  |

Note: With sideshift minus 330lb, with integral sideshift minus 220lb.

**DIMENSIONS**

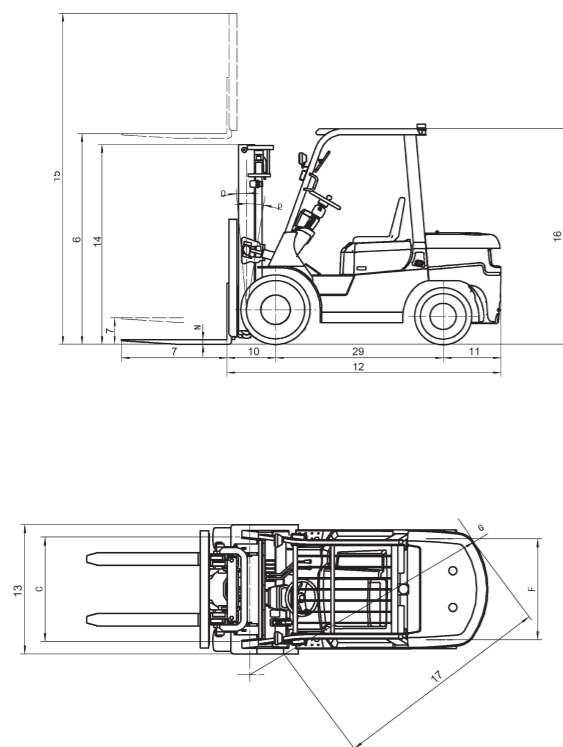

**LOAD CAPACITY CHART  
2-stage mast**

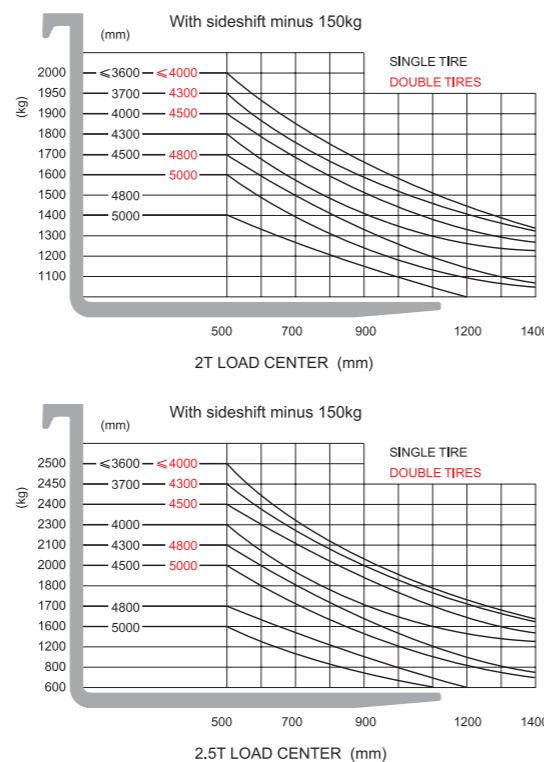

**LOAD CAPACITY CHART  
2-stage mast**

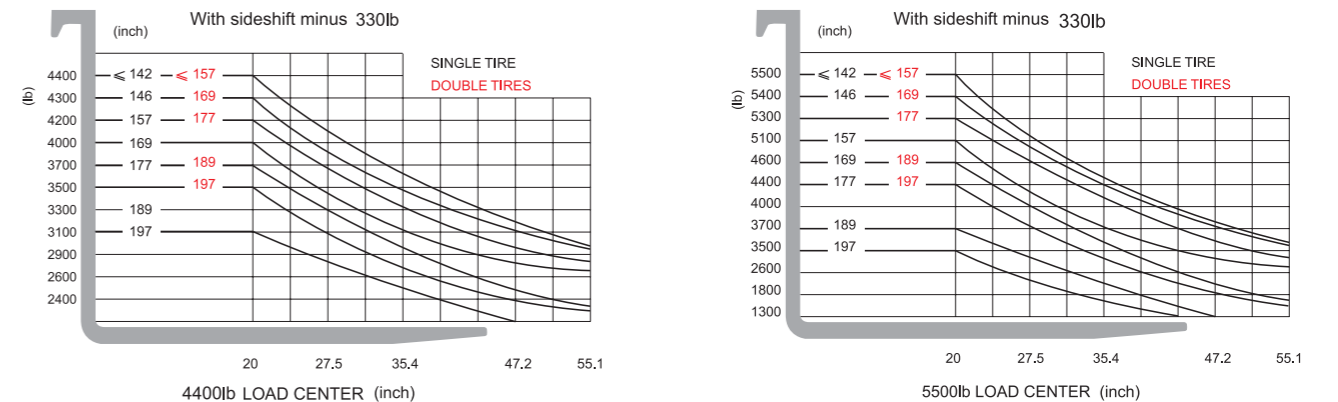

**3.0-3.5t T series mast: (Pneumatic)**

| Type                      | Model | Max.fork height | Overall height |                  |               |                  | Free lift     |      | Front Overhang |     | Tilt range |                        | Capacity |             |      |  |
|---------------------------|-------|-----------------|----------------|------------------|---------------|------------------|---------------|------|----------------|-----|------------|------------------------|----------|-------------|------|--|
|                           |       |                 | Lowered        | Extended         |               | Without backrest | With backrest | 3.0t | 3.5t           | FWD | BWD        | Load capacity at 500mm |          |             |      |  |
|                           |       |                 |                | Without backrest | With backrest |                  |               |      |                |     |            | Single tire            |          | Double tire |      |  |
|                           |       |                 |                |                  |               |                  |               |      |                |     |            | 3.0t                   | 3.5t     | 3.0t        | 3.5t |  |
| mm                        | mm    | mm              | mm             | mm               | mm            | mm               | mm            | Deg  | Deg            | kg  | kg         | kg                     | kg       |             |      |  |
| Wide view<br>2-stage mast | 2W300 | 3000            | 2025           | 3570             | 4250          | 120              | 120           | 440  | 440            | 6   | 12         | 3000                   | 3500     | 3000        | 3500 |  |
|                           | 2W330 | 3300            | 2145           | 3690             | 4370          | 120              | 120           | 440  | 440            | 6   | 12         | 3000                   | 3500     | 3000        | 3500 |  |
|                           | 2W350 | 3500            | 2245           | 3890             | 4570          | 120              | 120           | 440  | 440            | 6   | 12         | 3000                   | 3500     | 3000        | 3500 |  |
|                           | 2W360 | 3600            | 2295           | 3990             | 4670          | 120              | 120           | 440  | 440            | 6   | 12         | 3000                   | 3500     | 3000        | 3500 |  |
|                           | 2W400 | 4000            | 2495           | 4040             | 4720          | 120              | 120           | 440  | 440            | 6   | 12         | 2850                   | 3250     | 3000        | 3500 |  |
|                           | 2W430 | 4300            | 2645           | 4340             | 5020          | 120              | 120           | 440  | 440            | 6   | 6          | 2700                   | 3000     | 2900        | 3400 |  |
|                           | 2W450 | 4500            | 2745           | 4290             | 4970          | 120              | 120           | 440  | 440            | 6   | 6          | 2550                   | 2850     | 2850        | 3350 |  |
| Full free<br>2-stage mast | 2F300 | 3000            | 2080           | 2620             | 3300          | 1460             | 810           | 440  | 440            | 6   | 12         | 3000                   | 3500     | 3000        | 3500 |  |
|                           | 2F330 | 3300            | 2230           | 3870             | 4550          | 1610             | 960           | 440  | 440            | 6   | 12         | 3000                   | 3500     | 3000        | 3500 |  |
| Full free<br>3-stage mast | 3F430 | 4300            | 2000           | 5570             | 4910          | 1360             | 730           | 460  | 460            | 6   | 6          | 2550                   | 2550     | 2850        | 3350 |  |
|                           | 3F450 | 4500            | 2080           | 5750             | 5070          | 1460             | 810           | 460  | 460            | 6   | 6          | 2400                   | 2400     | 2700        | 3200 |  |
|                           | 3F480 | 4800            | 2125           | 6050             | 5375          | 1565             | 915           | 460  | 460            | 6   | 6          | 2250                   | 2250     | 2550        | 2900 |  |
|                           | 3F500 | 5000            | 2270           | 6250             | 5570          | 1610             | 960           | 460  | 460            | 6   | 6          | 2100                   | 2100     | 2400        | 2750 |  |
|                           | 3F550 | 5500            | 2350           | 6830             | 6150          | 1770             | 1120          | 460  | 460            | 3   | 6          | 1650                   | 1650     | 2250        | 2550 |  |
|                           | 3F600 | 6000            | 2770           | 7250             | 6570          | 2020             | 1370          | 460  | 460            | 3   | 6          | 1200                   | 1200     | 2100        | 2300 |  |

Note: With sideshift minus 200Kg, with integral sideshift minus 150Kg.

**6600-7700lb series mast: (Pneumatic)**

| Type                      | Model | Max.fork height | Overall height |                  |               |                  | Free lift     |        | Front Overhang |     | Tilt range |                          | Capacity |             |        |  |
|---------------------------|-------|-----------------|----------------|------------------|---------------|------------------|---------------|--------|----------------|-----|------------|--------------------------|----------|-------------|--------|--|
|                           |       |                 | Lowered        | Extended         |               | Without backrest | With backrest | 6600lb | 7700lb         | FWD | BWD        | Load capacity at 20 inch |          |             |        |  |
|                           |       |                 |                | Without backrest | With backrest |                  |               |        |                |     |            | Single tire              |          | Double tire |        |  |
|                           |       |                 |                |                  |               |                  |               |        |                |     |            | 6600lb                   | 7700lb   | 6600lb      | 7700lb |  |
| inch                      | inch  | inch            | inch           | inch             | inch          | inch             | inch          | Deg    | Deg            | lb  | lb         | lb                       | lb       |             |        |  |
| Wide view<br>2-stage mast | 2W300 | 118             | 80             | 141              | 167           | 4.7              | 4.7           | 17.3   | 17.3           | 6   | 12         | 6600                     | 7700     | 6600        | 7700   |  |
|                           | 2W330 | 130             | 84             | 145              | 172           | 4.7              | 4.7           | 17.3   | 17.3           | 6   | 12         | 6600                     | 7700     | 6600        | 7700   |  |
|                           | 2W350 | 138             | 88             | 153              | 180           | 4.7              | 4.7           | 17.3   | 17.3           | 6   | 12         | 6600                     | 7700     | 6600        | 7700   |  |
|                           | 2W360 | 142             | 90             | 157              | 184           | 4.7              | 4.7           | 17.3   | 17.3           | 6   | 12         | 6600                     | 7700     | 6600        | 7700   |  |
|                           | 2W400 | 157             | 98             | 159              | 186           | 4.7              | 4.7           | 17.3   | 17.3           | 6   | 12         | 6300                     | 7200     | 6600        | 7700   |  |
|                           | 2W430 | 169             | 104            | 171              | 198           | 4.7              | 4.7           | 17.3   | 17.3           | 6   | 6          | 6000                     | 6600     | 6400        | 7500   |  |
|                           | 2W450 | 177             | 108            | 169              | 196           | 4.7              | 4.7           | 17.3   | 17.3           | 6   | 6          | 5600                     | 6300     | 6300        | 7400   |  |
| Full free<br>2-stage mast | 2F300 | 118             | 82             | 103              | 130           | 57               | 32            | 17.3   | 17.3           | 6   | 12         | 6600                     | 7700     | 6600        | 7700   |  |
|                           | 2F330 | 130             | 88             | 152              | 179           | 63               | 38            | 17.3   | 17.3           | 6   | 12         | 6600                     | 7700     | 6600        | 7700   |  |
| Full free<br>3-stage mast | 3F430 | 169             | 79             | 219              | 193           | 54               | 29            | 18.1   | 18.1           | 6   | 6          | 5600                     | 5600     | 6300        | 7400   |  |
|                           | 3F450 | 177             | 82             | 226              | 200           | 57               | 32            | 18.1   | 18.1           | 6   | 6          | 5300                     | 5300     | 6000        | 7100   |  |
|                           | 3F480 | 189             | 84             | 238              | 212           | 62               | 36            | 18.1   | 18.1           | 6   | 6          | 5000                     | 5000     | 5600        | 6400   |  |
|                           | 3F500 | 197             | 89             | 246              | 219           | 63               | 38            | 18.1   | 18.1           | 6   | 6          | 4600                     | 4600     | 5300        | 6100   |  |
|                           | 3F550 | 217             | 93             | 269              | 242           | 70               | 44            | 18.1   | 18.1           | 3   | 6          | 3600                     | 3600     | 5000        | 5600   |  |
|                           | 3F600 | 236             | 109            | 285              | 259           | 80               | 54            | 18.1   | 18.1           | 3   | 6          | 2600                     | 2600     | 4600        | 5100   |  |

Note: With sideshift minus 440lb, with integral sideshift minus 330lb.

**LOAD CAPACITY CHART  
2-stage mast**

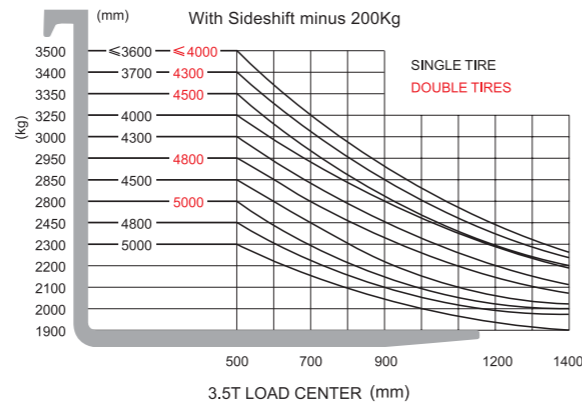
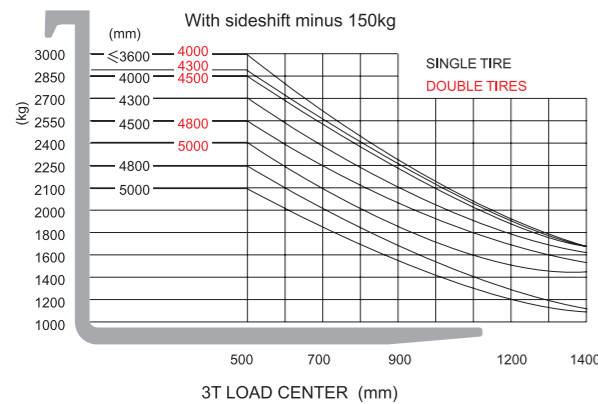

**LOAD CAPACITY CHART  
2-stage mast**

