

Customization is available
Products and specifications are
subject to be changed without notice

Options

- 2.0-5.0m / 79-197 inch duplex mast
- 2.5-4.0m / 98-157 inch full free duplex mast
- 4.3-6.5m./169-256 inch triplex mast
- Special carriage and backrest
- Other dimension forks
- Dual drive wheel with fender
- Solid tyre
- Colored tyre (white / green)
- Cabin
- Heater and air condition
- Fire extinguisher
- Semi-suspension seat or full-suspension seat
- Dual air cleaner or special air cleaner
- Rear working light
- Customer painting
- Auxiliary hydraulic valve modules
- High-mounted exhaust system
- Middle-mounted exhaust system
- Anti-fire spark exhaust device
- Diesel exhaust das purifier
- Radiator screen
- Side shifter
- Integrated side shifter
- Other attachment

E-P Equipment Co.,LTD
Let's grow together...



CE
ISO9000

T Series
1.5/1.8T
3000/4000lb
Diesel/Gasoline/LPG



24 hrs
 Service Change Your Business

East Power
EP Forklift Truck-T series
2 year warranty

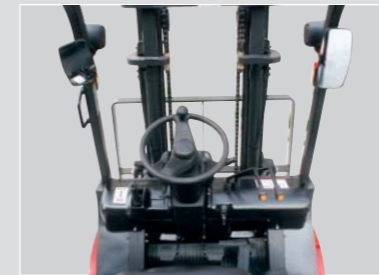

Wide-View Mast
 The operator is able to work with increased safety and accuracy due to a wider view mast.



Adjustable Steering Wheel
 Steering wheel can be adjusted by a lever on the right-hand side for the most comfortable operator position.



Easily-Detached Floor Panel
 One-touch removal of the floorboard gets you right to service operations and reduces down-time.



Simple, Small-Stroke F/R Lever
 The forward-reverse lever swings through a smaller arc than previous models, meaning less effort and less total time used during this basic, often-performed function.



Automobile-Style Light/Turn-Signal Lever
 The automotive influence seen in the T Series extends to the thoughtful use of an automobile-style light and turn-signal lever, with simple actions that let the operator focus on the job.



Wide-Open Operation Space
 The area between the foot pedals and the body below the seat is open and free of obstructions that hamper entering and exiting the forklift.



Option
 Special carriage and backrest
 Other dimension forks
 Dual drive wheel with fender
 Cabin
 Heater and air condition
 Dual air cleaner or special air cleaner
 Rear working light

Custom color paint
 High-mounted exhaust system
 Middle-mounted exhaust system
 Sideshifter
 Other attachment
 Lpg fuel system (single, dual)

T series 1.5-1.8t forklift specification:

General		DEP								
		FD15T-NE92	FG15-F2	FD18T-NE92	FG18T-F2					
1	Manufacture									
2	Model									
3	Power type	Diesel Gasoline Diesel Gasoline								
4	Rated capacity	Kg	1500	1500	1800	1800				
5	Load center	mm	500	500	500	500				
Characteristics & Dimensions		6	Lift height	mm	3000	3000	3000	3000		
		7	Free lift height	mm	120	120	120	120		
		8	Fork size	L*W*T	mm	920*80*40	920*80*40	920*80*40	920*80*40	
		9	Mast tilt range	F/R	deg	6/12	6/12	6/12	6/12	
		10	Fork overhang(wheel center to fork face)	mm	420	420	420	420		
		11	Rear overhang	mm	420	420	420	420		
		12	Overall dimensions	Length to face of fork	mm	2230	2230	2270	2270	
		13		Overall width	mm	1080	1080	1080	1080	
		14		Mast lowered height	mm	1995	1995	1995	1995	
		15		Mast extended height	mm	3960	3960	3960	3960	
16	Overhead guard height	mm	2070	2070	2070	2070				
17	Turning radius(outside)	mm	1995	1995	2035	2035				
18	Min.right angle stacking aisle width (Add load length and clearance)	mm	2400	2400	2440	2440				
19	AST with pallet 800*1000mm cross fork	mm	3560	3560	3600	3600				
Performance		20	Speed	Travel (No load)	Km/h	14	14	14	14	
		21		Lifting (Full load)	mm/sec	460	460	460	460	
		22		Lowering (Full load)	mm/sec	450	450	450	450	
		23	Max.Drawbar Pull (Full load)	N	20500(17500)	20500(17500)	20500(17500)	20500(17500)		
24	Max.Gradeability (Full load)	%	20	20	20	20				
Chassis		25	Tyres	Front		6.50-10-10PR	6.50-10-10PR	6.50-10-10PR	6.50-10-10PR	
		26		Rear		5.00-8-10PR	5.00-8-10PR	5.00-8-10PR	5.00-8-10PR	
		27	Tread	Font	mm	920	920	920	920	
		28		Rear	mm	920	920	920	920	
		29	Wheelbase	mm	1430	1430	1430	1430		
		30	Ground clearance	Lowest	mm	110	110	110	110	
31	Wheelbase center	mm		145	145	145	145			
Weight		32	Self weight	Kg	2700	2700	2900	2900		
		33	Weight Distribution	Full load	Front	Kg	3570	3570	3995	3995
		34			Rear	Kg	630	630	705	705
		35		No load	Front	Kg	1215	1215	1305	1305
		36			Rear	Kg	1485	1485	1595	1595
Power & transmission		37	Battery	Voltage/Capacity(20HR)	V/AH	12/60	12/60	12/60	12/60	
		38	Engine	Model		4TNE92	F2(2.2L)	4TNE92	F2(2.2L)	
		39		Manufacture		YANMAR	MAZDA	YANMAR	MAZDA	
		40		Rated output/r.p.m	kw	33/2450	37.2/2700	33/2450	37.2/2700	
		41		Rated torque/r.p.m	N.m	136/1600	142/1800	136/1600	142/1800	
		42		No.of cylinder		4	4	4	4	
		43		Bore*Stroke	mm	92*100	86*94	92*100	86*94	
		44		Displacement	cc	2659	2184	2659	2184	
		45		Fuel tank capacity	L	50	50	50	50	
		46	Transmissions	Manufacture		CHINA	CHINA	CHINA	CHINA	
47	Type			Powershift	Powershift	Powershift	Powershift			
48	Stage	FWD/RVS			1/1	1/1	1/1	1/1		
49	Operating pressure	For attachments	Mpa	17.5	17.5	17.5	17.5			

1. Special lifting height available. 2. Attachment available.
 3. The specification in the table are for standard models only . For further information please contact us.
 4. Specification are subject to be changed without notice.

T series 3300-4000lb forklift specification:

General		DEP								
		FD15T-NE92	FG15T-F2	FD18T-NE92	FG18T-F2					
1	Manufacture									
2	Model									
3	Power type	Diesel Gasoline Diesel Gasoline								
4	Rated capacity	lb	3300	3300	4000	4000				
5	Load center	inch	20	20	20	20				
Characteristics & Dimensions		6	Lift height	inch	118	118	118	118		
		7	Free lift height	inch	4.7	4.7	4.7	4.7		
		8	Fork size	L*W*T	inch	36.2*3.15*1.57	36.2*3.15*1.57	36.2*3.15*1.57	36.2*3.15*1.57	
		9	Mast tilt range	F/R	deg	6/12	6/12	6/12	6/12	
		10	Fork overhang(wheel center to fork face)	inch	16.5	16.5	16.5	16.5		
		11	Rear overhang	inch	16.5	16.5	16.5	16.5		
		12	Overall dimensions	Length to face of fork	inch	88	88	89	89	
		13		Overall width	inch	43	43	43	43	
		14		Mast lowered height	inch	79	79	79	79	
		15		Mast extended height	inch	156	156	156	156	
16	Overhead guard height	inch	81	81	81	81				
17	Turning radius(outside)	inch	79	79	80	80				
18	Min.right angle stacking aisle width (Add load length and clearance)	inch	94	94	96	96				
19	AST with pallet 800*1000mm cross fork	inch	140	140	142	142				
Performance		20	Speed	Travel (No load)	mile/h	8.7	8.7	8.7	8.7	
		21		Lifting (Full load)	inch/sec	18.1	18.1	18.1	18.1	
		22		Lowering (Full load)	inch/sec	17.7	17.7	17.7	17.7	
		23	Max.Drawbar Pull (Full load)	N	20500(17500)	20500(17500)	20500(17500)	20500(17500)		
24	Max.Gradeability (Full load)	%	20	20	20	20				
Chassis		25	Tyres	Front		6.50-10-10PR	6.50-10-10PR	6.50-10-10PR	6.50-10-10PR	
		26		Rear		5.00-8-10PR	5.00-8-10PR	5.00-8-10PR	5.00-8-10PR	
		27	Tread	Font	inch	36	36	36	36	
		28		Rear	inch	36	36	36	36	
		29	Wheelbase	inch	56	56	56	56		
		30	Ground clearance	Lowest	inch	4.3	4.3	4.3	4.3	
31	Wheelbase center	inch		5.7	5.7	5.7	5.7			
Weight		32	Self weight	lb	6000	6000	6400	6400		
		33	Weight Distribution	Full load	Front	lb	7900	7900	8800	8800
		34			Rear	lb	1400	1400	1600	1600
		35		No load	Front	lb	2700	2700	2900	2900
		36			Rear	lb	3300	3300	3500	3500
Power & transmission		37	Battery	Voltage/Capacity(20HR)	V/AH	12/60	12/60	12/60	12/60	
		38	Engine	Model		4TNE92	F2(2.2L)	4TNE92	F2(2.2L)	
		39		Manufacture		YANMAR	Mazda	YANMAR	Mazda	
		40		Rated output/r.p.m	hp	44/2450	50/2700	44/2450	50/2700	
		41		Rated torque/r.p.m	N.m	136/1600	142/1800	136/1600	142/1800	
		42		No.of cylinder		4	4	4	4	
		43		Bore*Stroke	inch	3.6*3.9	3.4*3.7	3.6*3.9	3.4*3.7	
		44		Displacement	cc	2659	2184	2659	2184	
		45		Fuel tank capacity	L	50	50	50	50	
		46	Transmissions	Manufacture		CHINA	CHINA	CHINA	CHINA	
47	Type			Powershift	Powershift	Powershift	Powershift			
48	Stage	FWD/RVS			1/1	1/1	1/1	1/1		
49	Operating pressure	For attachments	Mpa	17.5	17.5	17.5	17.5			

1. Special lifting height available. 2. Attachment available.
 3. The specification in the table are for standard models only . For further information please contact us.
 4. Specification are subject to be changed without notice.

1.5~1.8t T series mast: (Pneumatic)

Type	Model	Max.fork height	Overall height			Free lift		Front Overhang		Tilt range		Capacity			
			Lowered	Extended		Without backrest	With backrest	1.5t	1.8t	FWD	BWD	Load capacity at 500mm			
				Without backrest	With backrest							Single tire		Double tire	
			mm	mm	mm	mm	mm	mm	Deg	Deg	kg	kg	kg	kg	
Wide view 2-stage mast	2W300	3000	1995	3585	3955	120	120	420	420	6	12	1500	1800	1500	1800
	2W330	3300	2145	3885	4255	120	120	420	420	6	12	1500	1800	1500	1800
	2W350	3500	2245	4085	4455	120	120	420	420	6	12	1500	1800	1500	1800
	2W360	3600	2295	4185	4555	120	120	420	420	6	12	1500	1800	1500	1800
	2W400	4000	2545	4585	4955	120	120	420	420	6	12	1400	1600	1500	1800
	2W430	4300	2695	4885	5255	120	120	420	420	6	12	1300	1500	1400	1600
	2W450	4500	2795	5085	5455	120	120	420	420	6	6	1250	1400	1350	1500
Full free 2-stage mast	2F300	3000	2040	3605	3955	1345	1105	420	420	6	12	1500	1800	1500	1800
	2F330	3300	2190	3905	4255	1495	1165	420	420	6	12	1500	1800	1500	1800
Full free 3-stage mast	3F430	4300	1965	5070	5255	1425	1080	440	440	6	6	1250	1450	1350	1550
	3F450	4500	2045	5130	5465	1485	1140	440	440	6	6	1200	1350	1300	1450
	3F480	4800	2160	5445	5755	1575	1230	440	440	6	6	1100	1250	1200	1350
	3F500	5000	2210	5605	5955	1665	1320	440	440	6	6	1050	1150	1150	1250
	3F550	5500	2375	6120	6455	1825	1480	440	440	3	6	/	/	950	1050
	3F600	6000	2600	6695	6955	1975	1630	440	440	3	6	/	/	750	850

Note: With sideshift minus 150Kg, with integral sideshift minus 100Kg.

3300-4000lb T series mast: (Pneumatic)

Type	Model	Max.fork height	Overall height			Free lift		Front Overhang		Tilt range		Capacity			
			Lowered	Extended		Without backrest	With backrest	3300lb	4000lb	FWD	BWD	Load capacity at 20 inch			
				Without backrest	With backrest							Single tire		Double tire	
			inch	inch	inch	inch	inch	inch	inch	inch	Deg	Deg	lb	lb	lb
Wide view 2-stage mast	2W300	118	79	141	156	4.7	4.7	16.5	16.5	6	12	3300	4000	3300	4000
	2W330	130	84	153	168	4.7	4.7	16.5	16.5	6	12	3300	4000	3300	4000
	2W350	138	88	161	175	4.7	4.7	16.5	16.5	6	12	3300	4000	3300	4000
	2W360	142	90	165	179	4.7	4.7	16.5	16.5	6	12	3300	4000	3300	4000
	2W400	157	100	181	195	4.7	4.7	16.5	16.5	6	12	3100	3500	3300	4000
	2W430	169	106	192	207	4.7	4.7	16.5	16.5	6	6	2900	3300	3100	3500
	2W450	177	110	200	215	4.7	4.7	16.5	16.5	6	6	2800	3100	3000	3300
Full free 2-stage mast	2F300	118	80	142	156	53	44	16.5	16.5	6	12	3300	4000	3300	4000
	2F330	130	86	154	168	59	46	16.5	16.5	6	12	3300	4000	3300	4000
Full free 3-stage mast	3F430	169	77	200	207	56	43	17.3	17.3	6	6	2800	3200	3000	3400
	3F450	177	81	202	215	58	45	17.3	17.3	6	6	2600	3000	2900	3200
	3F480	189	85	214	227	62	48	17.3	17.3	6	6	2400	2800	2600	3000
	3F500	197	87	221	234	66	52	17.3	17.3	6	6	2300	2500	2500	2800
	3F550	217	94	241	254	72	58	17.3	17.3	3	6	/	/	2100	2300
	3F600	236	102	264	274	78	64	17.3	17.3	3	6	/	/	1700	1900

Note: With sideshift minus 330lb, with integral sideshift minus 220lb.

DIMENSIONS

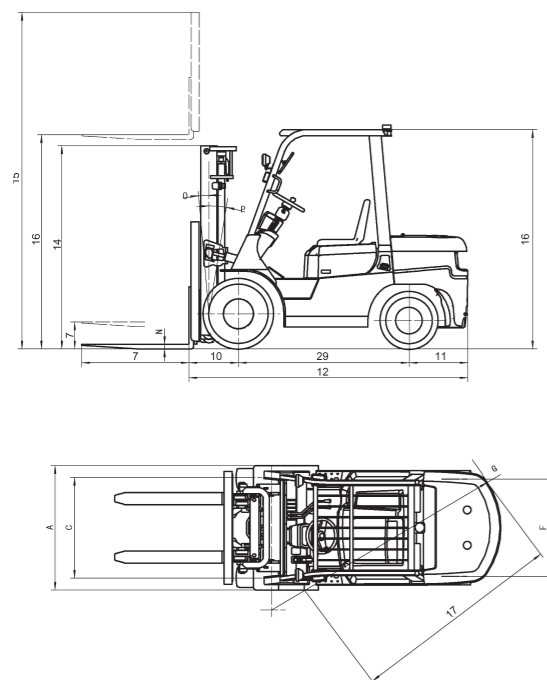

LOAD CAPACITY CHART
2-stage mast

