



# DIG 156

**AvK**<sup>®</sup>

Model	DIG 156
Maximum continuous rating at 50Hz (kVA)	10,000
Maximum continuous rating at 60Hz (kVA)	11,000

Specifications	
Voltage Range	3,300-13,800
Poles	4, 6, 8, 10
Technology	Bar Wound
AVR	Digital
Voltage sensing	3-Phase
Bearing Arrangement	Double (Sleeve Bearings)
Terminals	6
Material Insulation Class	F
Excitation System	Auxiliary Winding
Ingress Protection	IP23
Temperature monitoring	Winding RTDs
Connection with other machines	Paralleling capability

## DIMENSIONS

Drawings represent standard design  
 All dimensions in millimetres (mm)

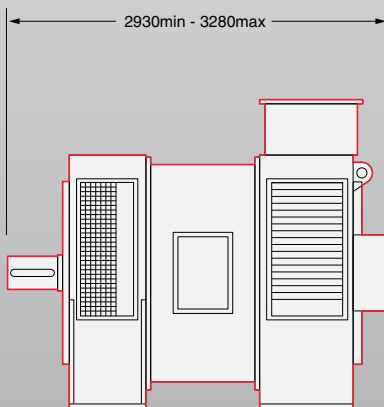
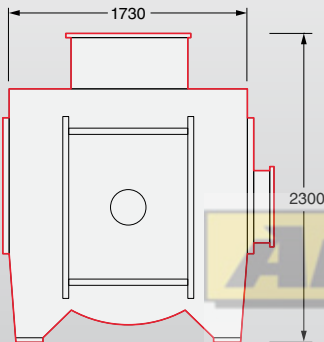

Optional Features	
Ingress Protection	IP23 Air Filters
Ingress Protection	IP44/54/55/56 Totally enclosed
Cooling options	CACA/CACW
Environmental protection	Anti-condensation Heaters

Designed For	
Power Plant	●
Grid Code Compatible	●
Marine Propulsion	●
Oil & Gas	●
Combined Heat & Power	●
Continuous Power & Standby	●

Prime Movers	
Diesel Engine	●
Gas Engine	●
Gas Turbine	●
Steam Turbine	●



High Voltage

6,000 - 20,000 KVA