

AvK®

DIG 120

Model	DIG 120
Maximum continuous rating at 50Hz (kVA)	2,050
Maximum continuous rating at 60Hz (kVA)	2,600

Specifications	
Voltage Range	3,300-11,000
Poles	4
Technology	Bar Wound
AVR	Digital
Voltage sensing	3-Phase
Bearing Arrangement	Double
SAE Adaptors	1, 0, 00
Terminals	6
Material Insulation Class	F
Excitation System	Auxiliary Winding
Ingress Protection	IP23
Temperature monitoring	Winding RTDs
Connection with other machines	Paralleling capability

Optional Features	
Bearing Arrangement	Sleeve Bearings
Ingress Protection	IP23 Air Filters
Ingress Protection	IP44/54/55/56 Totally enclosed
Cooling options	CACA/CACW
Environmental protection	Anti-condensation Heaters

Designed For	
Power Plant	●
Grid Code Compatible	●
Marine Propulsion	
Oil & Gas	●
Combined Heat & Power	●
Continuous Power & Standby	●

Prime Movers	
Diesel Engine	●
Gas Engine	●
Gas Turbine	●
Steam Turbine	●



DIMENSIONS

Drawings represent standard design
 All dimensions in millimetres (mm)

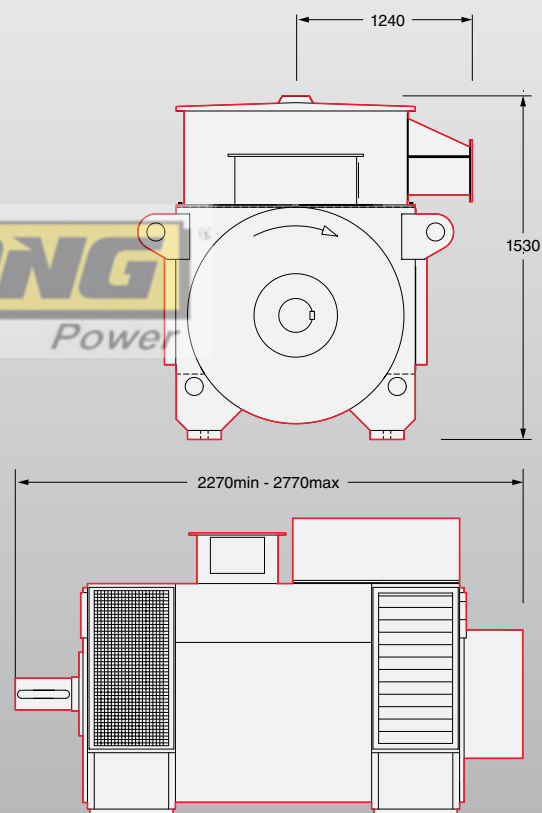

High Voltage

1,000 - 6,000 kVA